

SEEPEX.

An Ingersoll Rand Business

FOR THICK PRODUCTS
PRODUCT GROUP T
BTVE, BTHE, BTH RANGES

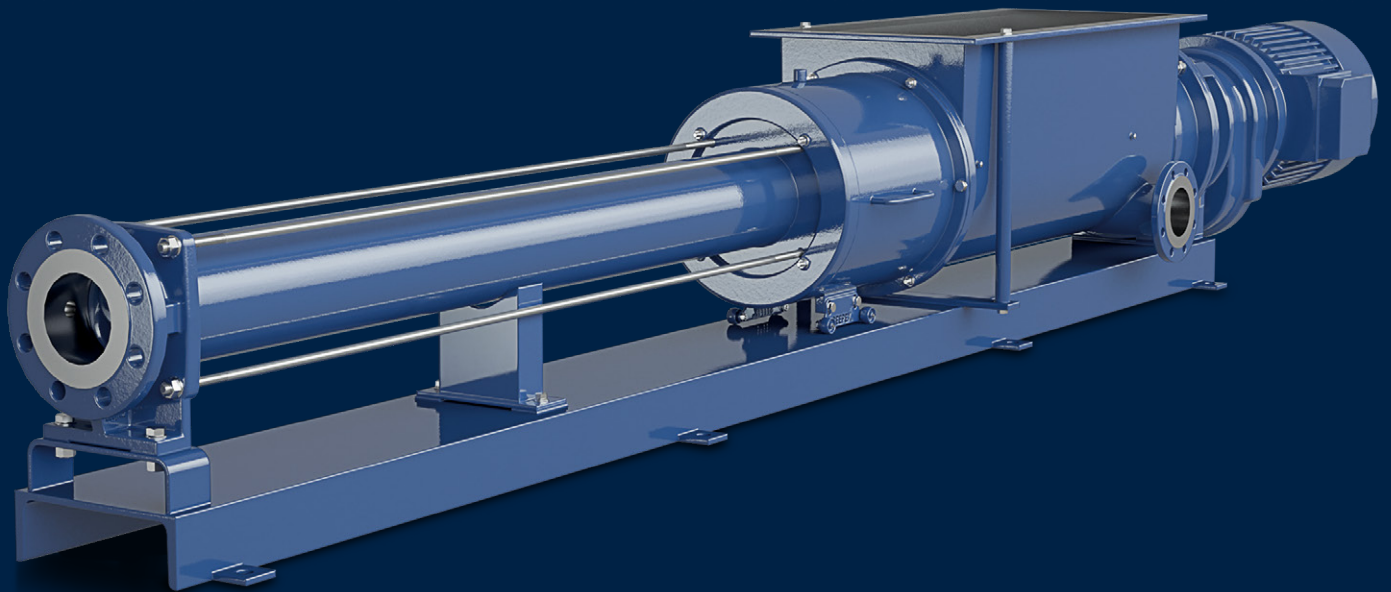

BTVE

BTHE

BTH

OPTIMAL FEEDING.

BTVE, BTHE and BTH range open hopper pumps are made with a feed hopper and feed screw, for pumping highly viscous non flowable products with a high dry solids content.

BTHE RANGE

BTHE range pumps feature a concentrically rotating ribbon screw and a full screw in the compression casing. This guarantees optimum emptying of the feed hopper and optimized feed of the product into the conveying elements of the pump.

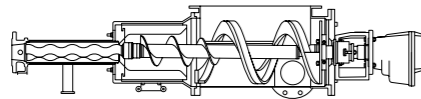

BTVE RANGE

BTVE range pumps feature a sliding compression casing with an enlarged cross section to simplify service. A solid auger feed screw with a long pitch, enlarged diameter and increased blade thickness for durability enables longer operating times.

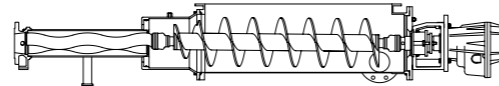

BTH RANGE

This range is characterized by a separately driven, concentrically rotating ribbon screw with a maximized diameter and a long pitch length. Through separate control of the conveying screw speed, the BTH pump can be used for almost any conveying media. The BTH range is the technical optimum solution for shear-sensitive products.

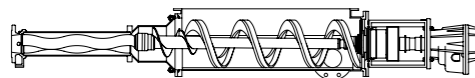

APPLICATIONS

BTVE, BTHE and BTH pumps are suitable for many applications in agriculture; renewable energy; breweries and distilleries; ceramics; paint, varnishes and electroplating; fish, meat and poultry processing; paper and cellulose; wood; textiles; chemicals, petrochemicals and bio-chemicals and environmental waste disposal.

They also expertly handle dewatered sludge in wastewater treatment plants, fermentation substrates for biogas production, fruit and vegetable waste and also paper stock.

FEATURES

- Enlarged feed hopper with vertical walls to prevent bridging
- Feed hopper length adjusted according to the customer's operating conditions
- Sliding compression casing offers increased ease of maintenance and productivity
- Flanged connection on the hopper for flushing or dilution
- Interchangeable ranges with identical installation dimensions

KEY FACTS

- Conveying capacity:
up to 120 m³/h (530 USGPM)
- Pressure:
up to 36 bar (525 psi)
- Dry solids content:
BTVE: up to 32%
BTHE: up to 45%
BTH: up to 45%

FOR HIGH VISCOSITY: BTVE.

BTVE range pumps are equipped with an enlarged rectangular feed hopper, a separate sliding compression casing with an enlarged cross section and an auger feed screw with an extended pitch and enlarged diameter. These pumps are used for conveying highly viscous products. By sliding the compression casing, it is possible to access and disassemble the rotor-sided joint with the pressure branch and stator in place. This results in increased ease of maintenance.

ROTOR AND STATOR

Optimized compression between the rotor and stator using wear-resistant and corrosion-resistant materials. A wide range of alloys, coatings and elastomers are available for each.

FEED HOPPER

With vertical hopper walls to prevent bridging or clogging and a generous cross section. The hopper length can be individually fabricated.

SHAFT SEAL

Packing or mechanical seals are available in many material combinations.

COMPRESSION CASING

Sliding separate casing with enlarged cross section ensures quick and easy maintenance.

AUGER FEED SCREW

Designed with increased blade thickness, a long pitch and enlarged diameter for optimal product feeding.

FLUSH CONNECTION

Connection for cleaning, emptying or diversion.

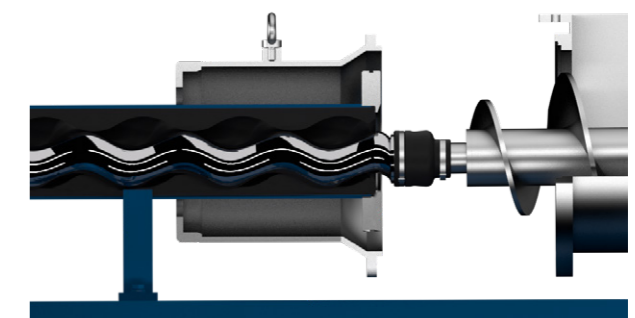

OPEN COMPRESSION CASING

The sliding casing allows access to the rotor universal joint, enabling removal of the rotor and stator.

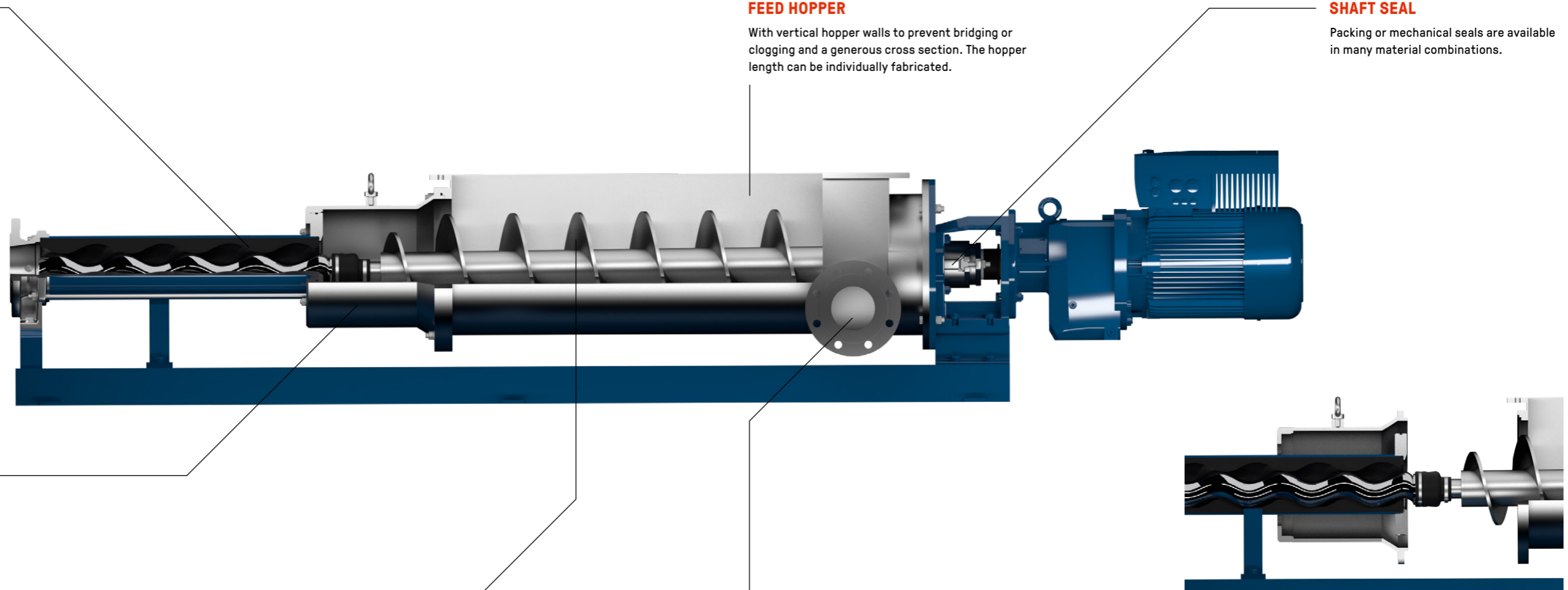

FOR HIGH DRY SOLIDS: BTHE AND BTH.

BTHE and BTH range pumps are equipped with an enlarged rectangular feed hopper, a separate compression casing and an auger feed screw with an extended pitch and enlarged diameter. These pumps are used for conveying viscous products with a high dry solids content that are prone to bridging. The roller-mounted compression casing consists of a detachable conical inlay for quick and easy maintenance of the rotor-side joint.

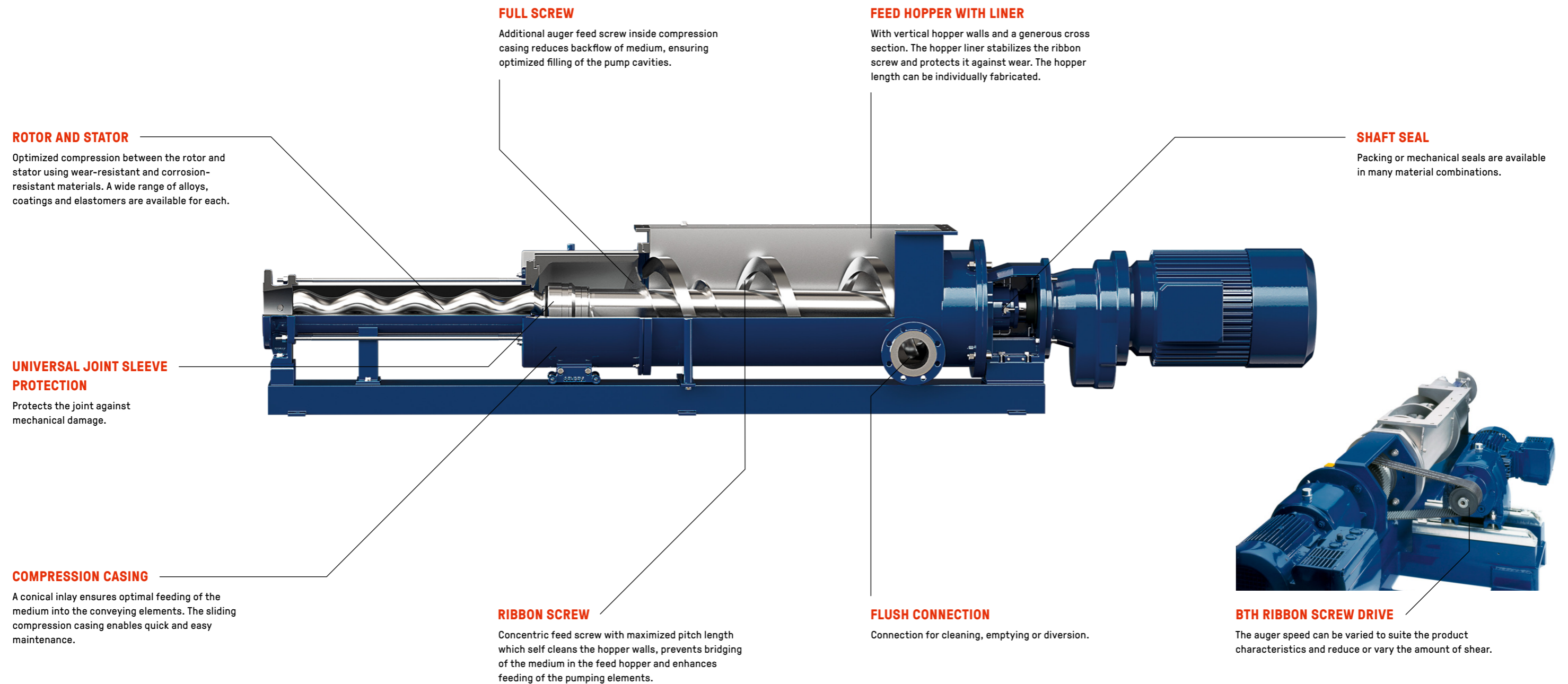

ROTOR AND STATOR

Optimized compression between the rotor and stator using wear-resistant and corrosion-resistant materials. A wide range of alloys, coatings and elastomers are available for each.

FULL SCREW

Additional auger feed screw inside compression casing reduces backflow of medium, ensuring optimized filling of the pump cavities.

FEED HOPPER WITH LINER

With vertical hopper walls and a generous cross section. The hopper liner stabilizes the ribbon screw and protects it against wear. The hopper length can be individually fabricated.

SHAFT SEAL

Packing or mechanical seals are available in many material combinations.

UNIVERSAL JOINT SLEEVE PROTECTION

Protects the joint against mechanical damage.

COMPRESSION CASING

A conical inlay ensures optimal feeding of the medium into the conveying elements. The sliding compression casing enables quick and easy maintenance.

RIBBON SCREW

Concentric feed screw with maximized pitch length which self cleans the hopper walls, prevents bridging of the medium in the feed hopper and enhances feeding of the pumping elements.

FLUSH CONNECTION

Connection for cleaning, emptying or diversion.

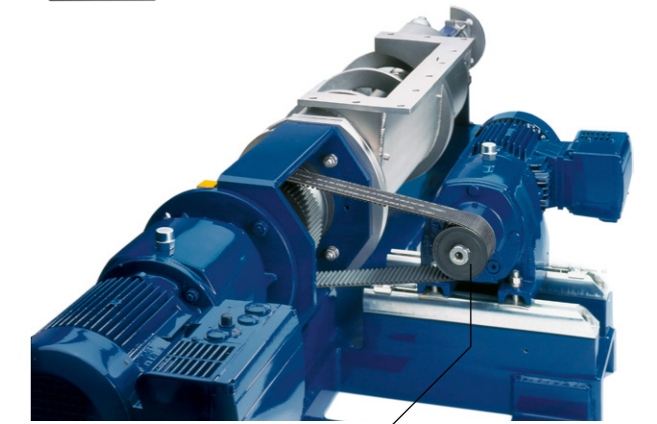

BTH RIBBON SCREW DRIVE

The auger speed can be varied to suite the product characteristics and reduce or vary the amount of shear.

SEEPEX.

An Ingersoll Rand Business

SEEPEX GmbH

www.seepex.com